

QUEEN60

Spiral mixer with fixed bowl Dough capacity Kg 60



- Mixing **capacity 60 kg.**
- Recommended hydration from **55% to 100%.**
- Variable **speed 70/300 rpm.**
- Touch screen control panel.
- Infrared rays temperature sensor.
- Reverse bowl rotation.
- Retractable castors.
- Heavy-duty stainless-steel bowl, spiral arm, and breaking bar.
- Safety stainless-steel grid over the bowl.
- Non-toxic powdered epoxy certified coating.
- Electrical system and safety devices made in accordance with CE regulation.

OPERATION

- Make sure the machine is off.
- Raise the bowl guard until it stops against the rubber rest.
- Load the machine with ingredients of the type and quantity required.
- Lower the bowl guard on its rest.
- Set the touch screen panel by selecting required parameters of the desired recipe.
- Push the icon "Start" in order to start from the first working phase.
- Once the mixing is complete, empty the bowl.

Touch screen panel legend: described in the user manual.

QUEEN60

Spiral mixer with fixed bowl
Dough capacity Kg 60



DIMENSIONS & CAPACITY

MAX DOUGH CAPACITY	60 kg/132 lb
MIN DOUGH CAPACITY	6 kg/13 lb
FLOUR CAPACITY	36 kg/79 lb
BOWL VOLUME	86 qt
A - LENGTH	23"
B - DEPTH	39"
C - HEIGHT	43"

TECHNICAL SPECIFICATION

VOLTAGE	230V/60Hz/3-Phase+N
MOTOR #	2
Speed	Variable 70/300 rpm
POWER	3500 W
AMP	15
HP	4,76
WEIGHT	551 lb

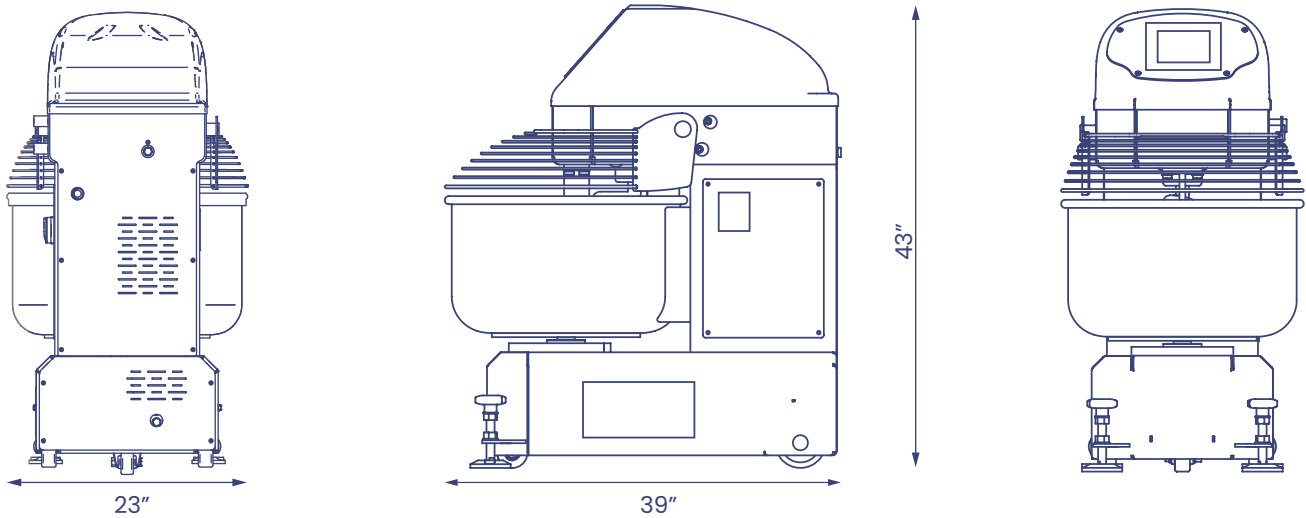

PACKAGING SPECIFICATION

HEAVY DUTY WOODEN CRATE

A - LENGTH	51"
B - DEPTH	33"
C - HEIGHT	51"
CRATE WEIGHT	216 lb
GROSS WEIGHT	767 lb

