

SUN60 CL

Spiral mixer with fixed bowl
Dough capacity Kg 60



- Mixing **capacity 60 kg.**
- Recommended **hydration from 55% to 100%.**
- Double speed: **1st speed 105 rpm, 2nd speed 210 rpm.**
- Double automatic timer.
- Reverse bowl rotation.
- Control panel at the top of the machine.
- Belt transmission.
- Retractable castors.
- Heavy-duty stainless-steel bowl, spiral arm, and breaking bar.
- Bottom of the bowl in hemispherical shape.
- Safety stainless-steel grid over the bowl.
- Pre-lubricated ball bearing transmission.
- Non-toxic powdered epoxy certified coating.
- Electrical system and safety devices made in accordance with CE regulation.

OPERATION

- Make sure the machine is off.
- Raise the bowl guard until it stops against the rubber rest.
- Load the machine with ingredients of the type and quantity required.
- Lower the bowl guard on its rest.
- Set the switch to position 1 (pilot lamp illuminates to indicate proper power supply voltage).
- Set the machine according to your recipe, rotation direction, 1st speed timer, and 2nd speed timer.
- Push the button "Start" in accordance with the desired speed.
- Once the mixing is complete, empty the bowl.

Touch screen panel legend: described in the user manual.

SUN60 CL

Spiral mixer with fixed bowl
Dough capacity Kg 60



DIMENSIONS & CAPACITY

MAX DOUGH CAPACITY	60 kg/132 lb
MIN DOUGH CAPACITY	6 kg/13 lb
FLOUR CAPACITY	36 kg/79 lb
BOWL VOLUME	86 qt
A - LENGTH	23"
B - DEPTH	39"
C - HEIGHT	43"

TECHNICAL SPECIFICATION

VOLTAGE	230V/60Hz/3-Phase-N
MOTOR #	2
SPEEDS #	2
1st SPEED	105 rpm
2st SPEED	210 rpm
POWER	3500 W
AMP	16
HP	4,76
WEIGHT	552 lb

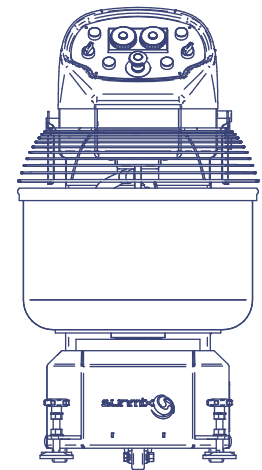
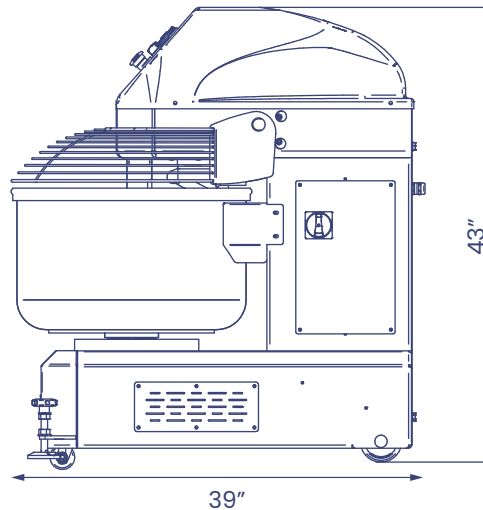
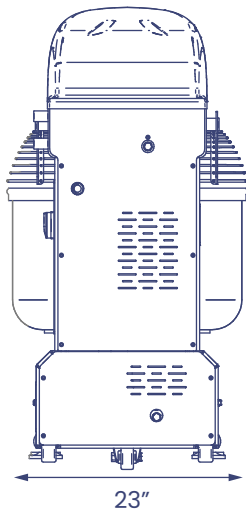

PACKAGING SPECIFICATION

HEAVY DUTY WOODEN CRATE

A - LENGTH	51"
B - DEPTH	33"
C - HEIGHT	51"
CRATE WEIGHT	216 lb
GROSS WEIGHT	768 lb



SUN60 CL

Spiral mixer with fixed bowl
Dough capacity Kg 60



CONTROL PANEL

BUTTONS LEGEND

- A** First speed
- B** Second speed
- C** Bowl rotation (with first speed)
- D** Bowl jog push-button (with open grid)
- E** Stop
- F** Emergency button



For safety reasons the mixer is delivered without a plug, a licensed electrician is required to connect it to the outlet.